



EMPACOTADORA VERTICAL TIGRA VPN25



TIGRA VPN25 VERTICAL PACKING MACHINE



EMPAQUETADORA VERTICAL TIGRA VPN25



ARV - ALRICANDE



> Para formar, encher e fechar pacotes almofada e fundo quadrado.

> Rápida e eficiente com acionamento através de servomotor.

> Produção de até 70 pacotes por minuto.

> Precisão e Economia

> Forming, filling and sealing of pouches and flat bottom packages.

> Quick and efficient, servomotor activated.

> Up to 70 packages per minute output.

> Precision and low cost

> Para formar, llenar y cerrar empaques tipo pouch y de fondo cuadrado.

> Rápida y eficiente, accionada através de servomotor.

> Producción de hasta 70 paquetes por minuto.

> Precisión y economía

# ESPECIFICAÇÕES TÉCNICAS - TECHNICAL SPECIFICATIONS - ESPECIFICACIONES TÉCNICAS

EMPAQUETADORA VERTICAL TIGRA VPN25 - TIGRA VPN25 VERTICAL PACKING MACHINE - EMPAQUETADORA VERTICAL TIGRA VPN25

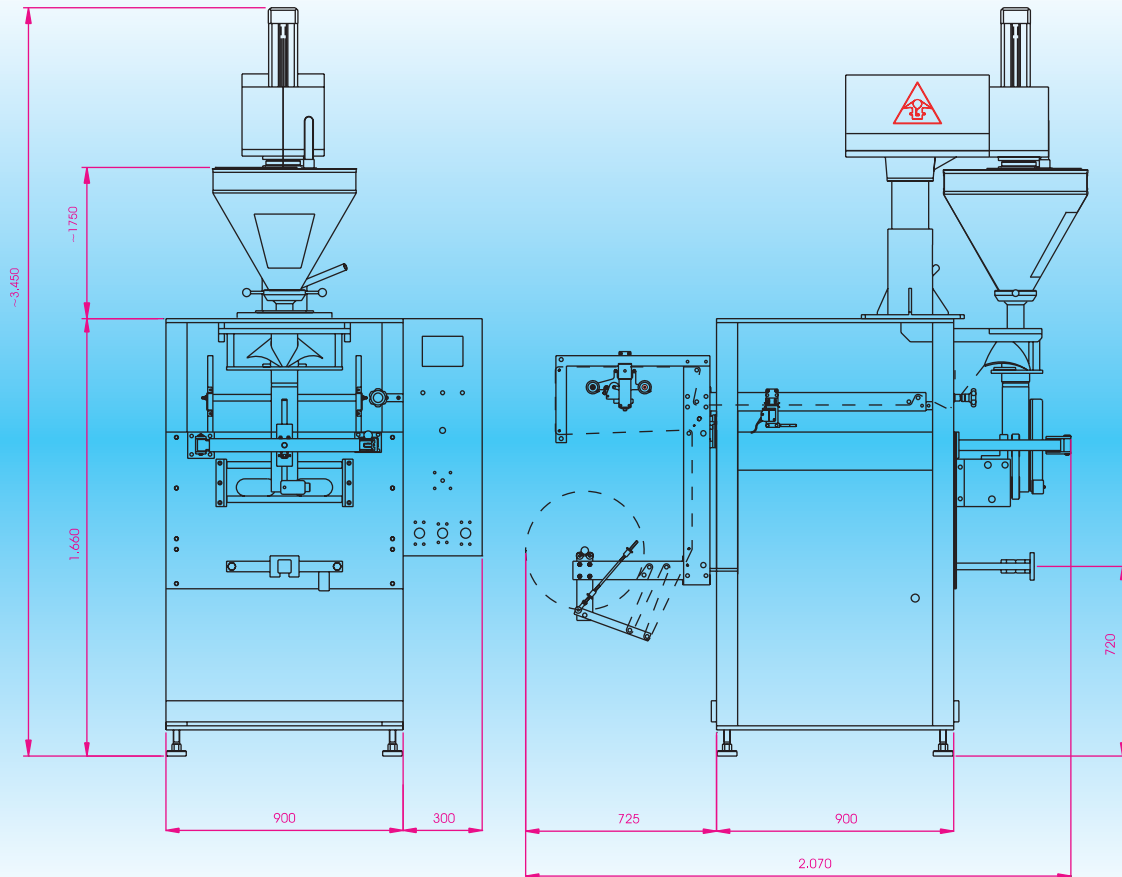

Larg. embalagem - <i>Packaging width - Ancho del empaque</i>	até 250 mm
Comp. embalagem - <i>Packaging length - Longitud del empaque</i>	até 400 mm
Larg. do Filme - <i>Web width - Ancho de la película</i>	até 530 mm
Ø int. bobina - <i>Roll internal Ø - Ø interno del rollo</i>	76 mm
Ø ext. bobina - <i>Roll external Ø - Ø externo del rollo</i>	350 mm
Cap. de produção - <i>Output capacity - Capacidad de producción</i>	até 60 pct / min
Dimensões da máquina - <i>Equipment dimensions - Dimensiones del equipo</i>	1300 x 1700 x 1955 mm
Espaço p/ inst. máq. - <i>Required space for installing - Espacio necesario para la instalación</i>	3200 x 3500 x 3200 mm
Consumo de ar - <i>Air consumption - Consumo de aire</i>	500 / 1000 NL / min
Pressão do ar - <i>Air pressure - Presión del aire</i>	7 bar
Tensão elétrica - <i>Voltage - Voltaje</i>	220 / 380 V
Cons. elétrico por aquecimento - <i>Elect. consumption for heating - Consumo eléctrico por calentamiento</i>	4,0 kW
Cons. elétrico por impulso - <i>Elect. consumption for pulse - Consumo eléctrico por impulso</i>	5,0 kW



ARV IND. MÁQUINA DE EMBALAGEM E COMÉRCIO DE PEÇAS LTDA.  
Rua Munhoz de Melo, 242/276 - Jd. Danfer - São Paulo - SP - CEP: 03729-030  
Tel.: (11) 6943-5010 - Fax: (11) 6943-1440  
comercial@arv-alricande.com.br - www.arv-alricande.com.br